

CROSS-CONNECTION CONTROL AND BACKFLOW PREVENTION SPECIFICATIONS



**THE ISLAND WATER ASSOCIATION, INC.
SANIBEL, FLORIDA**

Revised

11/05/2003

TABLE OF CONTENTS

Installation Instructions	PAGE	1 - 2
Double Check 3/4" to 2"	DWG. NO.	K - 9
Double Check 3" & Larger	DWG. NO.	K-10
Reduced Pressure 3/4" to 2"	DWG. NO.	K -11
Reduced Pressure 3" & Larger	DWG. NO.	K - 12

INSTALLATION INSTRUCTIONS FOR BACKFLOW PREVENTION ASSEMBLIES

1. No backflow assembly installation shall be accepted until it has been inspected, tested and certified by IWA.
2. Pipelines should be thoroughly flushed to remove foreign material and debris before installing device.
3. The assembly should be installed in the horizontal position unless otherwise specified by the manufacturer and approved by IWA.
4. The plumber may choose to install the backflow device using either 45° or 90° elbows.
5. The assembly shall be installed a minimum of 12 inches above ground from the bottom of the lowest point of assembly. In areas where installation of assembly may be in a low area subject to flooding such as a drainage or retention area, the height shall be determined by IWA.
6. All Backflow prevention devices must be the same size or larger than the meter to which they are connected.
7. Above-ground assemblies shall be installed with a minimum of 7 feet of clearance above and 2 feet at all sides for testing and maintenance.
8. All assemblies shall be installed before the first branch line of the service and as close as possible to the meter on the customer side. If the need arises to install an assembly at any other location than the meter due to lack of space, it shall be approved by IWA.
9. All assemblies shall be installed with adequate support independent of the piping system to prevent the assembly from moving and imposing loads on the piping system.
10. Special consideration should be given to the location and appearance of the assembly. There are several things which can be done to improve its appearance, such as:
 - Double check assemblies less than 2 inch can be placed in an underground vault (see sheet K-9)
 - The assembly can be painted to allow it to blend in with its surroundings
 - Landscaping can be used to screen the assembly, provided minimum clearances are met (see line 7)
11. All assemblies are to be approved by the American Water Works Association
 - AWWA C510-97 Standard for Double Check Valve Backflow Prevention assembly, and
 - AWWA C511-97 Standard for Reduced-Pressure Principle Backflow-Prevention assembly,and have met completely the laboratory and field performance specifications of the Foundation for Cross-Connection Control and Hydraulic Research of the University of Southern California established by "Specification of Backflow-Prevention Assemblies" -- Sec. 10 of the most current issue of the Manual of Cross-Connection Control.

The following manufacturers have been approved to provide devices to IWA: **1) Conbraco; 2) Wilkins; 3) Febc.** All other manufacturers are not approved.

12. All customers who have a backflow prevention device installed on their system shall be notified of the possible hazards due to thermal expansion. An example of this notification is:

WARNING

BACKFLOW ASSEMBLIES INSTALLED ON MEMBER'S SERVICE LINES WITH WATER HEATERS MAY CAUSE EXCESSIVE PRESSURE INCREASES IN YOUR WATER HEATER AND PLUMBING SYSTEM DUE TO THERMAL EXPANSION. THIS PROBLEM HAS BEEN ADDRESSED BY THE SOUTHERN STANDARD PLUMBING CODE TABLE (613.2 THERMAL EXPANSION CONTROL) AND SHOULD BE NOTED BY YOUR PLUMBER:

13. If the device is used for a fire sprinkler system:

- It must meet the local fire district and NFPA codes and these specifications.
- It must be a double-check detector type (DCDA) device. Above-ground installation required.
- It must have its own strainer conforming to local fire district and NFPA codes.
- And is multi-family or commercial, it must be connected directly to the main with its own separate backflow prevention device and isolation valve located at the edge of the members' property.
- And is not metered, it must have an installed flow detection device, and must be monitored and inspected in accordance with the local fire department requirements.

14. All lines longer than 50 feet and larger than 2" will require a HRS permit.

15. All work in the right of way will require a City utility permit for Sanibel and county utility permit for Captiva.

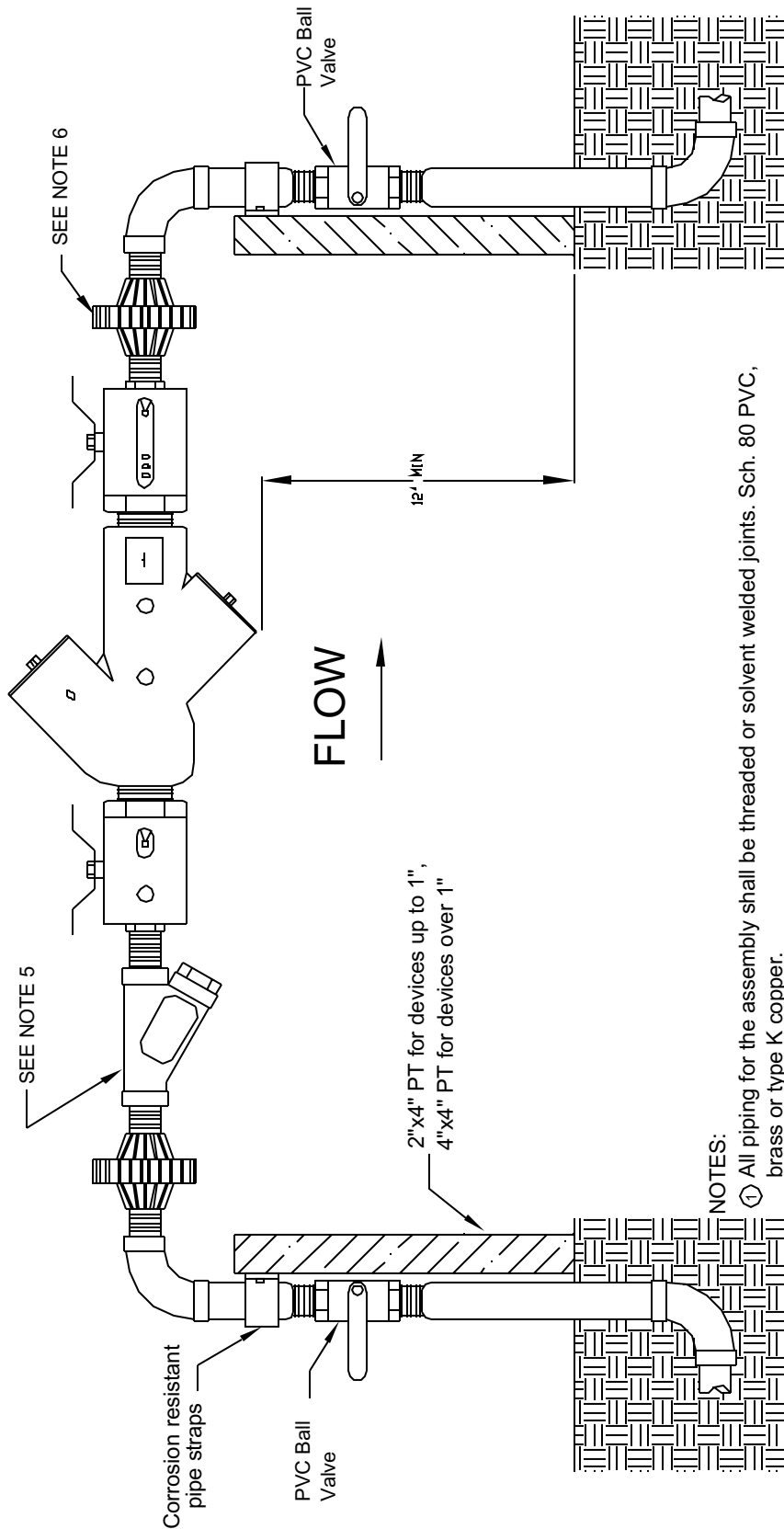

NOTES:

- ① All piping for the assembly shall be threaded or solvent welded joints. Sch. 80 PVC, brass or type K copper.
- ② Unprotected connections are prohibited between the backflow preventer and the meter.
- ③ Adequate support is required for all installations.
- ④ All nuts and bolts shall be stainless steel.
- ⑤ Strainers are required on 2" assemblies and optional on smaller assemblies.
- ⑥ All assemblies require 2 unions to allow the backflow preventer to be removed without cutting the pipe.
- ⑦ Double check assemblies may be installed in an underground vault provided there is a minimum of 12" clearance on all sides, between the vault and the assembly.

THE ISLAND WATER ASSOCIATION, INC.

3651 SANIBEL-CAPTIVA ROAD, SANIBEL FL 33957
 TELEPHONE: (941) 472-1502 - FAX: (941) 472-1505
 INTERNET: www.islandwater.com

**TYPICAL DOUBLE CHECK
 BACKFLOW ASSEMBLY
 INSTALLATION 2 IN. AND LESS**

DATE REVISIONS	REV
9-17-01	N/A
SCALE: 1" = 000'	
K-9	

FLOW →

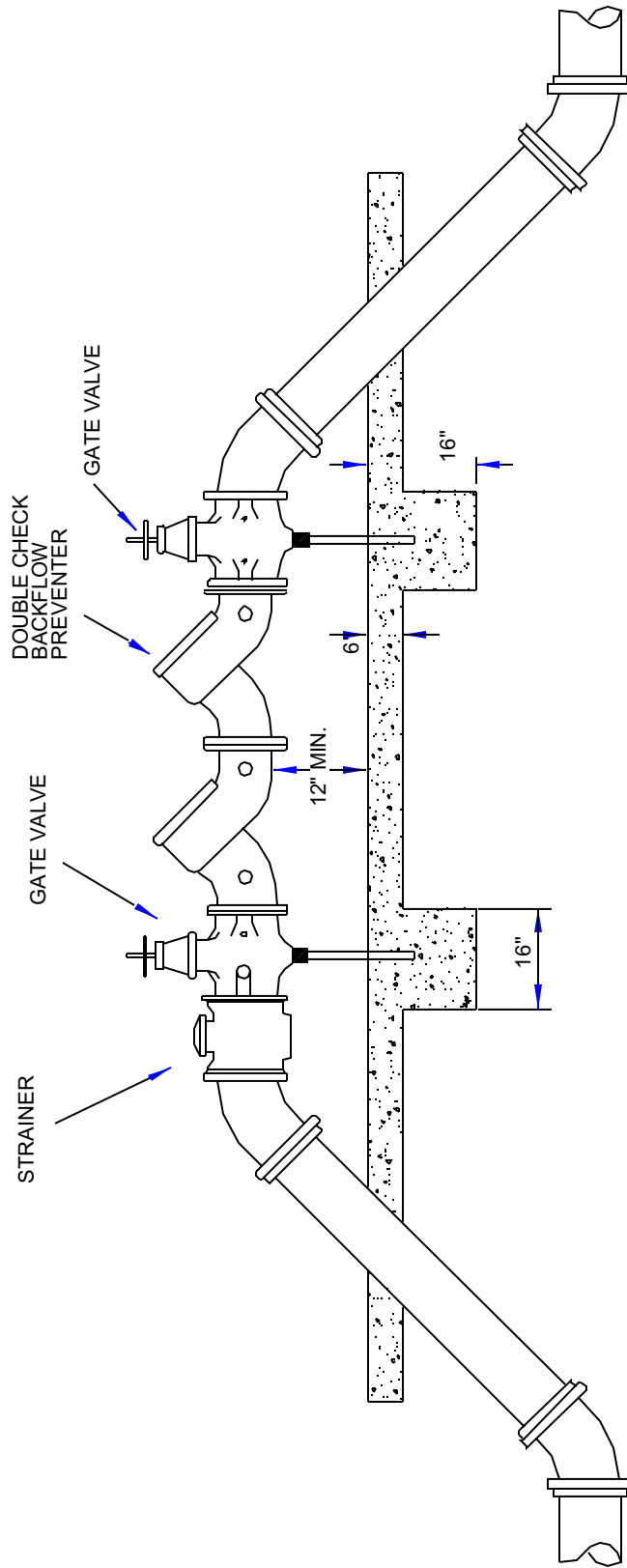

NOTES:

- ① ALL ABOVE GROUND PIPES SHALL BE CEMENT LINED D.I.P. CLASS 51, WITH FLANGED ENDS.
- ② ALL BELOW GROUND JOINTS SHALL BE RESTRAINED.
- ③ ALL NUTS AND BOLTS SHALL BE STAINLESS STEEL.
- ④ CONCRETE FOUNDATION TO BE FULL LENGTH OF THE ASSEMBLY.
- ⑤ UNPROTECTED CONNECTIONS ARE PROHIBITED BETWEEN THE BACKFLOW PREVENTER AND THE METER.

THE ISLAND WATER ASSOCIATION, INC.

3651 SANIBEL-CAPTIVA ROAD, SANIBEL FL 33957
 TELEPHONE: (941) 472-1502 - FAX: (941) 472-1505
 INTERNET: www.islandwater.com

**TYPICAL DOUBLE CHECK
 BACKFLOW ASSEMBLY
 INSTALLATION LARGER THAN 2 IN.**

DATE	REVISED	REV
2-4-00		N/A
SCALE 1" = 000'		
K-10		

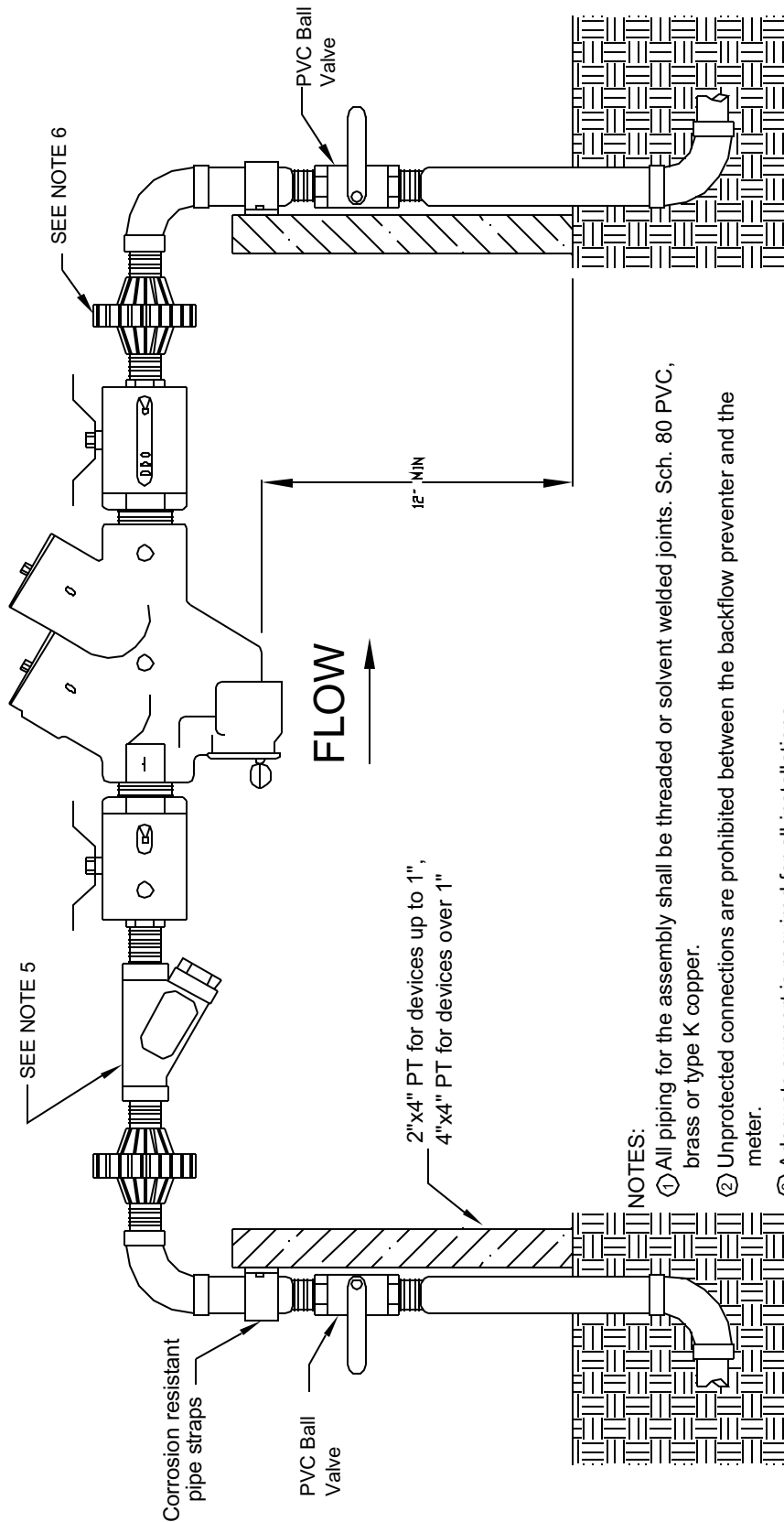

NOTES:

- ① All piping for the assembly shall be threaded or solvent welded joints. Sch. 80 PVC, brass or type K copper.
- ② Unprotected connections are prohibited between the backflow preventer and the meter.
- ③ Adequate support is required for all installations.
- ⑦ All nuts and bolts shall be stainless steel.
- ⑤ Strainers are required on 2" assemblies and optional on smaller assemblies.
- ⑥ All assemblies require 2 unions to allow the backflow preventer to be removed without cutting the pipe.

THE ISLAND WATER ASSOCIATION, INC.
 3651 SANIBEL-CAPTIVA ROAD, SANIBEL FL 33957
 TELEPHONE: (941) 472-1502 - FAX: (941) 472-1505
 INTERNET: www.islandwater.com

**TYPICAL REDUCED PRESSURE
 BACKFLOW ASSEMBLY
 INSTALLATION 2 IN. AND LESS**

DATE REVISIONS	REV
9-17-01	N/A
SCALE: 0" = 000'	
K-11	

FLOW →

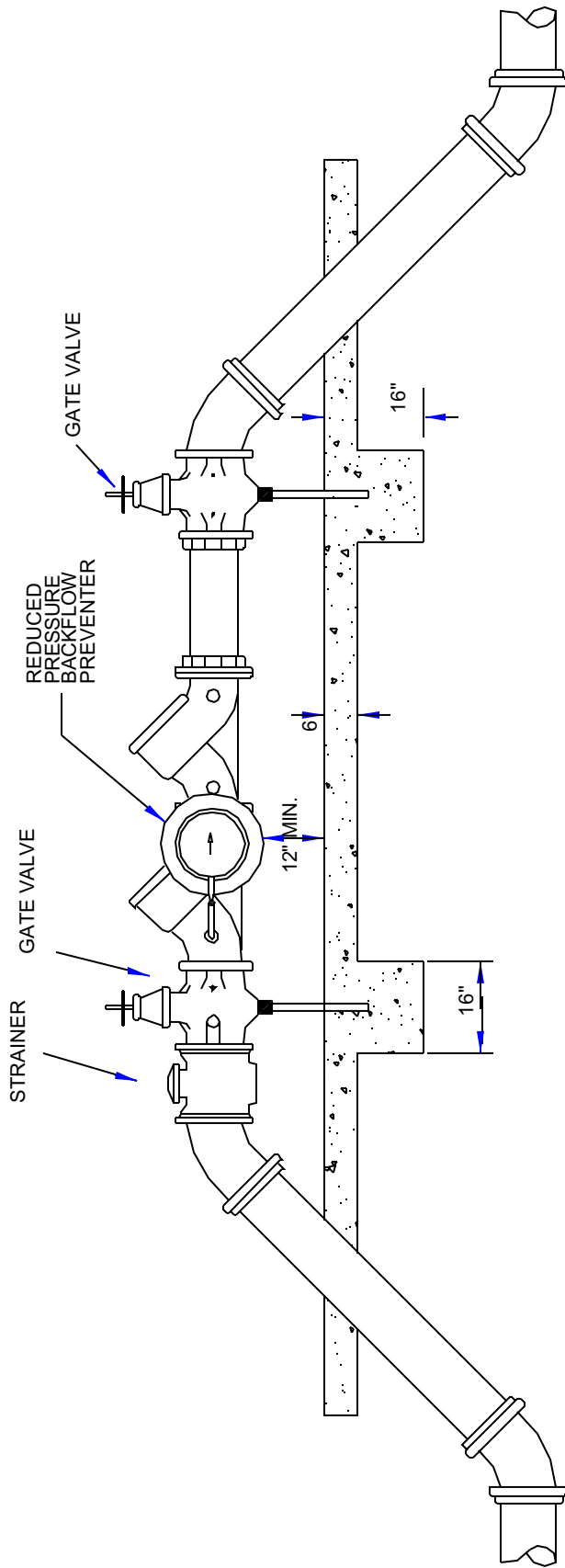

NOTES:

- ① ALL ABOVE GROUND PIPES SHALL BE CEMENT LINED D.I.P. CLASS 51, WITH FLANGED ENDS.
- ② ALL BELOW GROUND JOINTS SHALL BE RESTRAINED.
- ③ ALL NUTS AND BOLTS SHALL BE STAINLESS STEEL.
- ④ CONCRETE FOUNDATION TO BE FULL LENGTH OF THE ASSEMBLY.
- ⑤ UNPROTECTED CONNECTIONS ARE PROHIBITED BETWEEN THE BACKFLOW PREVENTER AND THE METER.

THE ISLAND WATER ASSOCIATION, INC.

3651 SANIBEL-CAPTIVA ROAD, SANIBEL FL 33957
 TELEPHONE: (941) 472-1502 - FAX: (941) 472-1505
 INTERNET: www.islandwater.com

TYPICAL REDUCED PRESSURE
 ASSEMBLY INSTALLATION LARGER
 THAN 2 IN

DATE	REVISED	REV
2-4-00		N/A
SCALE 1" = 000'		
K-12		